

Scania 10x4 mit 135 M/to Kran

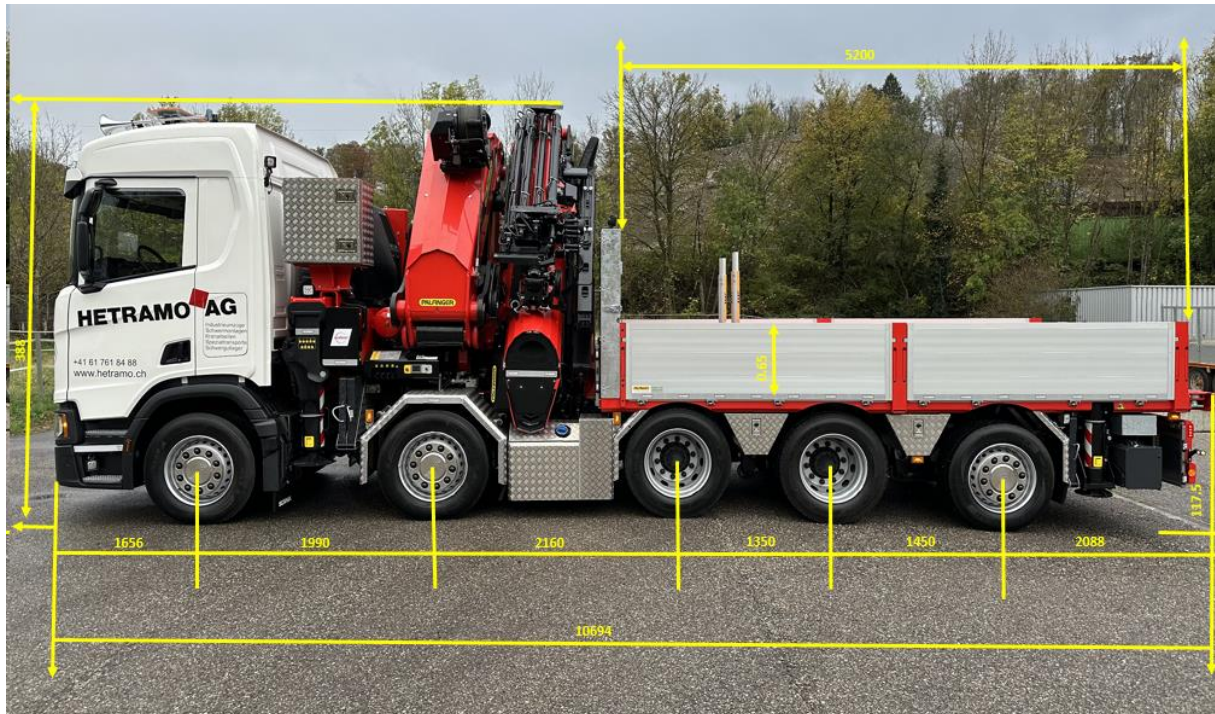

Scania 10x4 R 560

Brückenlänge:	5'400 mm
Breite:	2'550 mm
Beladehöhe:	2'825 mm
Nutzlast:	ohne Fly Jip 9'200 kg/ mit Fly Jip 7'660 kg
Max. Gesamtzuggewicht:	40'000 kg/ 60'000 kg
Spezielle Ausrüstung:	Frontabstützung Seilwinde 3'500 kg Containerverriegelung 20 Fuss Arbeitskorb für Arbeiten in der Höhe Vorder- und Hinterachsen luftgedert

HETRAMO AG

Scania 10x4 mit 135 M/to Kran

Tel: +41 61 761 84 88

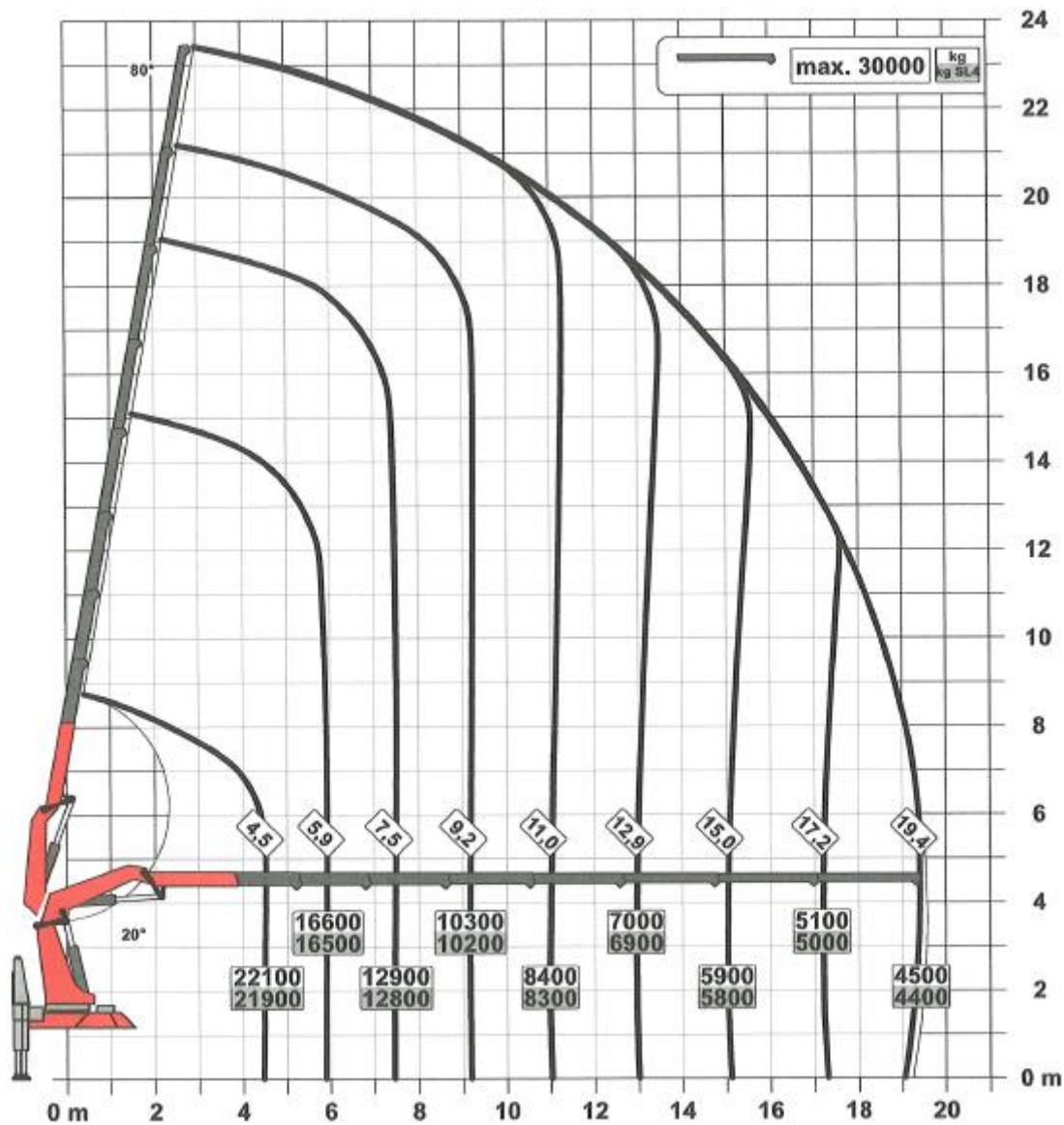

HETRAMO AG

Scania 10x4 mit 135 M/to Kran

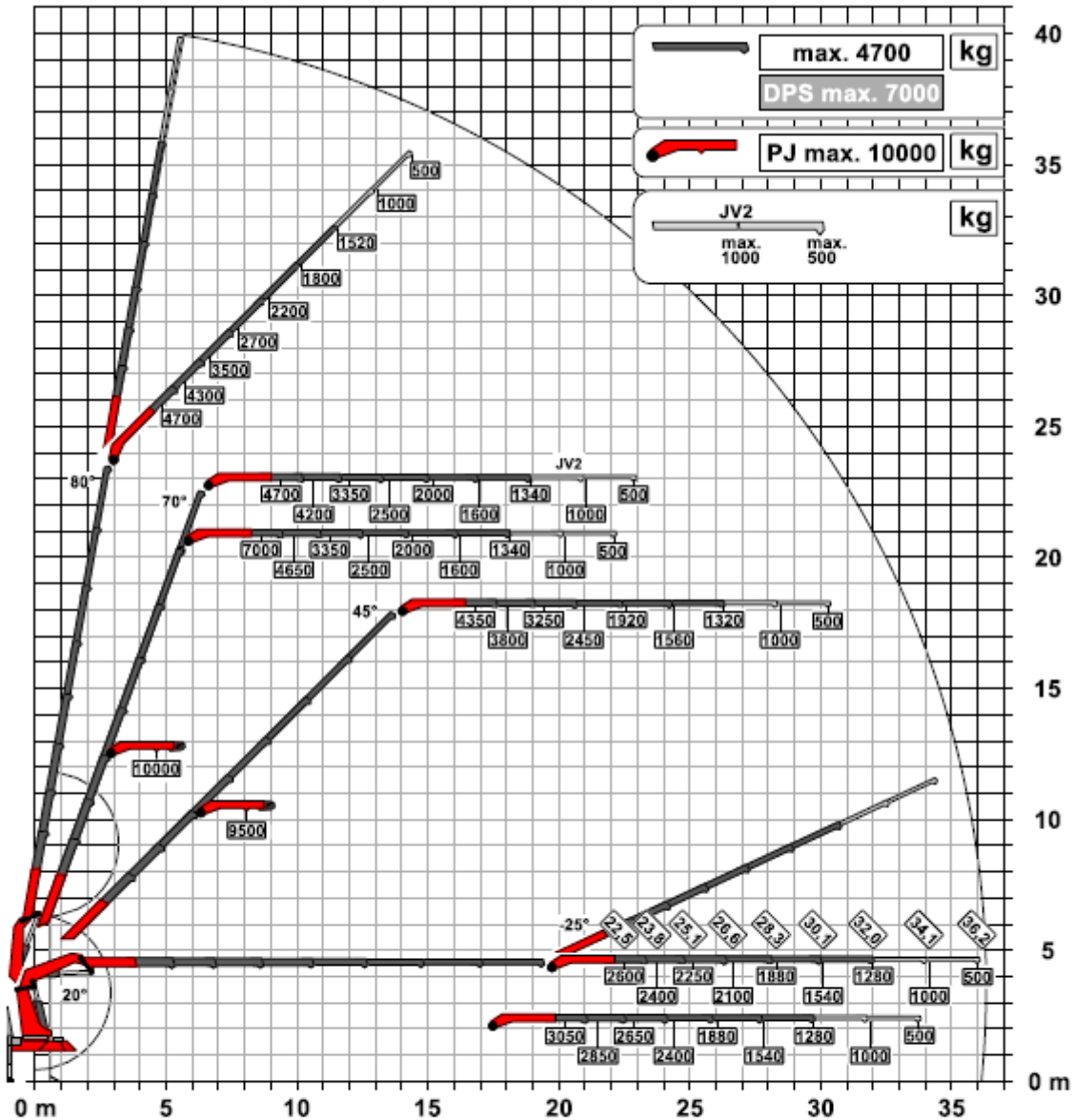

Eigengewicht: JV2
75 kg

Die Tragkräfte laut Diagramm verringern sich bei Verwendung von mechanischen Verlängerungen um deren Eigengewicht.
Die Tragkräfte laut Diagramm verringern sich bei Verwendung von Schlauchrüstung am Fly-Jib.

HETRAMO AG

Scania 10x4 mit 135 M/to Kran



SKY 3 300 REG ACCIAIO STEEL	900x1800x1230 mm	360° CONT	204 Kg	300 Kg	1 Kv	3
--------------------------------------	------------------	--------------	--------	--------	------	---

Richiesto limitatore di carico e kit Fullmatic in conformità con la norma EN 280
Kit Fullmatic & limiting device needed for Norm EN 280

*Dal piano di calpestio
**Inside the basket*

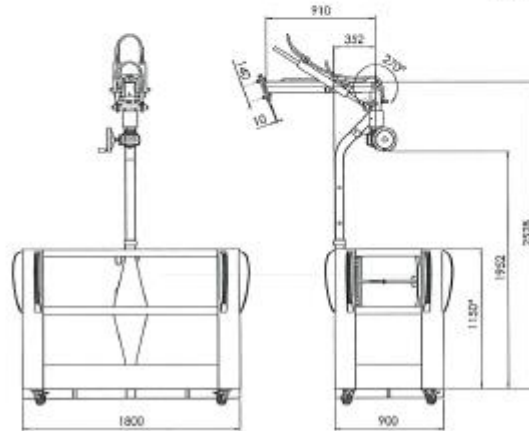

► Possibilità di installare sistema di autobilanciamento - **Kit SKY AUTO**
*Possibility to install self levelling system - **Kit SKY AUTO***

